

## CONTENTS

PARTS LIST .....	4
UNPACKING AND INSTALLATION .....	5
12 Volt dc supply .....	11
Connecting the power supply to a 12 Volt dc supply (battery) .....	12
DISMANTLING AND REPACKING THE MICROSCOPE .....	12
USE OF THE MICROSCOPE .....	13
Initial positioning .....	13
Positioning during use .....	13
Sterilisation .....	14
CARE AND MAINTENANCE .....	15
Care of the optical head .....	15
Fuse change .....	15
Care of the lamp .....	16
Lamp replacement .....	16
Focus friction .....	17
Power supply .....	17
Mould pellet replacement .....	17
<b>INSTALLING CAMERA EQUIPMENT .....</b>	<b>18</b>
Video camera and monitor .....	18
Attaching the 35mm camera adapter .....	20
Disassembling the 35mm camera adapter .....	20
<b>BINOCULAR ASSISTANT MICROSCOPE .....</b>	<b>22</b>
Mounting the binocular assistant microscope .....	22
TROUBLE SHOOTING .....	25
SPECIFICATIONS .....	27
Optical head .....	27
Lamphouse .....	27
Power supply .....	28
Mounting system .....	28
Case .....	28
SO-1370 Video Camera Watec WAT-202B CCD.....	29
SO-1380 Monitor Orion Combi 650 LCD.....	30

ISSUE NUMBER: 5.0	SUPERSEDES ISSUE: 4.1	WRITTEN BY: RJK	CHECKED BY: RDW
DATE: 11/04/02	DATE: 02/01/02	DATE: 08/10/98	DATE: 08/10/98

## LIST OF FIGURES

Figure 1	Scan Optics SO-111 Ophthalmic Microscope .....	3
Figure 2	Setting the mains voltage .....	5
Figure 3	Attaching the clamp to the mounting surface .....	6
Figure 4	Attaching the arm assembly .....	6
Figure 5	Attaching the microscope assembly .....	7
Figure 6	Connecting the lamphouse cable .....	8
Figure 7	Connecting the power supply .....	9
Figure 8	Inserting the eyepieces and rough focusing .....	10
Figure 9	Inserting the focus and zoom control covers .....	11
Figure 10	Mould pellet replacement .....	17
Figure 11	Video system schematic .....	19
Figure 12	Assembling the 35mm camera attachments .....	21
Figure 13	Binocular assistant microscope .....	22
Figure 14a	Changing the assistant microscope configuration .....	23
Figure 14b	Changing the assistant microscope configuration .....	24

ISSUE NUMBER: 5.0	SUPERSEDES ISSUE: 4.1	WRITTEN BY: RJK	CHECKED BY: RDW
DATE: 11/04/02	DATE: 02/01/02	DATE: 08/10/98	DATE: 08/10/98

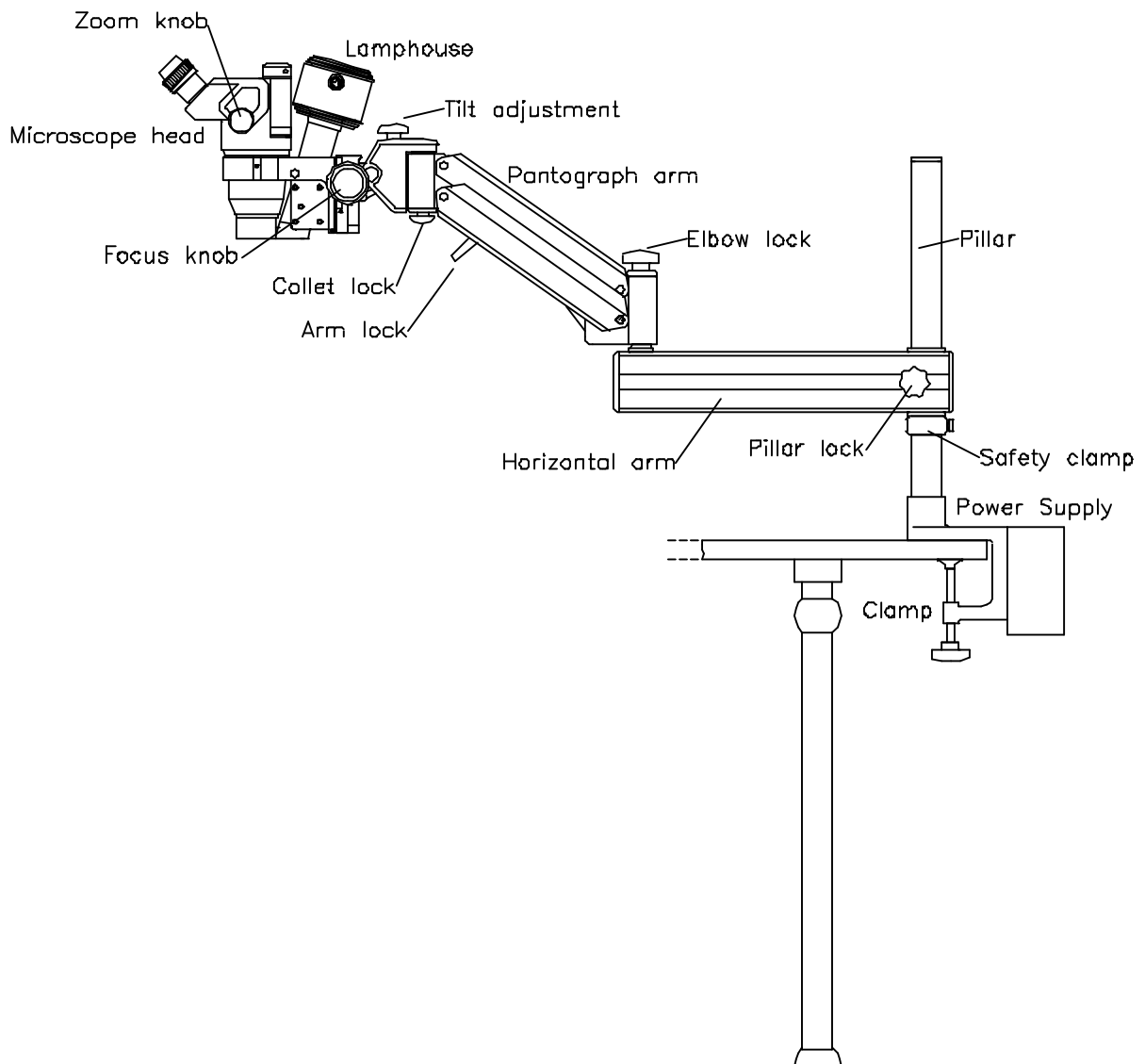

*Figure 1* Scan Optics SO-111 Ophthalmic Microscope

ISSUE NUMBER: 5.0	SUPERSEDES ISSUE: 4.1	WRITTEN BY: RJK	CHECKED BY: RDW
DATE: 11/04/02	DATE: 02/01/02	DATE: 08/10/98	DATE: 08/10/98

## INSTRUCTIONS AND SPECIFICATIONS

Please read the following information carefully before installing and using the Scan Optics Ophthalmic microscope. Scan Optics is responsible for the safety, reliability and performance of the equipment only if it is used in accordance with these instructions.

### PARTS LIST

#### MAIN ASSEMBLIES

Clamp assembly (includes power supply, clamp and pillar and safety clamp)

Arm assembly (includes horizontal arm and adjustable pantograph arm)

Microscope assembly (includes microscope head, lamphouse, and tilt adjuster)

#### CABLES

Lamphouse cable

Mains power cable

12V dc supply (battery) Cable

#### OTHER

Focus control covers (4)

Zoom control covers (4)

#### (OPTIONAL) FLOOR STAND

Base (1)

Pillar (1)

Arm mount (1)

#### TOOL KIT

Eyepieces (2)

Spare lamps (1)

Spare fuses (2)

Spare lamp (1)

Socket keys (set 7: 1 x 1.5mm, 1 x 2mm, 1 x 2.5mm, 1 x 3mm, 2 x 4mm,, 1 x 6mm)

Lens Cloth

#### OPTIONAL ACCESSORIES

#### SCAN OPTICS PART NUMBER

Binocular assistant microscope

SO-1420

Complete coaxial video system

SO-1350

Coaxial digital camera and printer

SO-1355

35 mm coaxial camera

SO-1375

Auxiliary light source

SO-232

Table plate

SO-291

Floor stand

SO-311

ISSUE NUMBER: 5.0	SUPERSEDES ISSUE: 4.1	WRITTEN BY: RJK	CHECKED BY: RDW
DATE: 11/04/02	DATE: 02/01/02	DATE: 08/10/98	DATE: 08/10/98

## UNPACKING AND INSTALLATION

1. Remove the clamp assembly from the case.
2. Check that the power supply is set to the correct mains voltage (110-120V or 220-240V), by noting the position of the indicator on the power supply near the mains input plug housing (see figure 2). **Severe damage can occur if the setting is incorrect.**

M If the mains voltage indicator is not correctly set, reposition it using a coin.

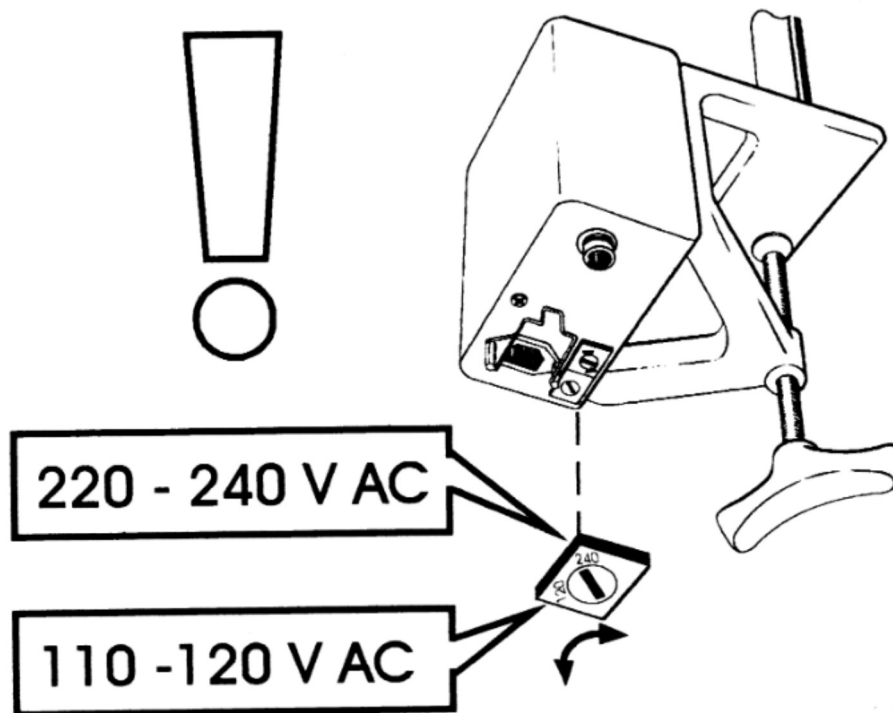

Figure 2 Setting the mains voltage

3. Fix the clamp to the operating table about 40 cm from the head of the table. The clamp may be fixed on either side of the table. Make sure that the clamp is pressed firmly against the side of the table before tightening (see figure 3).

M Alternatively, the clamp may be mounted on any horizontal surface that can be positioned within 60 cm of the working position, such as a mobile trolley.

M It is important that the mounting surface be free from vibration and movement. Note that in cases where the mounting surface is not rigid, over-tightening of the vertical clamp will not improve microscope stability. In this case, add a stiffening plate (such as Scan Optics Table Plate; Cat No. SO-291) beneath the mounting surface and apply the clamp over the stiffening plate and the original mounting surface.

ISSUE NUMBER: 5.0	SUPERSEDES ISSUE: 4.1	WRITTEN BY: RJK	CHECKED BY: RDW
DATE: 11/04/02	DATE: 02/01/02	DATE: 08/10/98	DATE: 08/10/98

4. Tighten the safety clamp at a point about midway up the pillar (see figure 3).

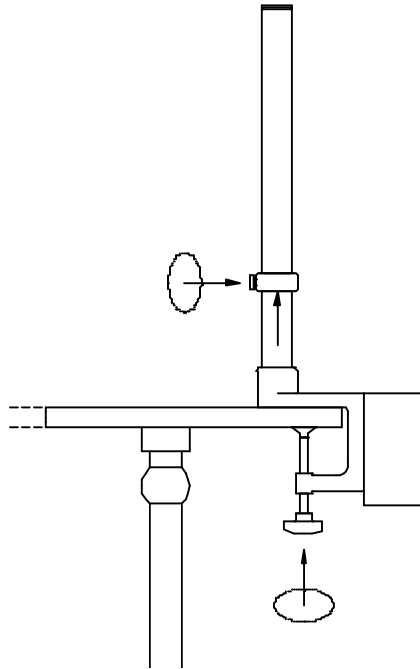

*Figure 3* Attaching the clamp to the mounting surface

5. Remove the arm assembly from the case, and place it on the pillar. Make sure that the arm assembly rests against the safety clamp (see figure 4).

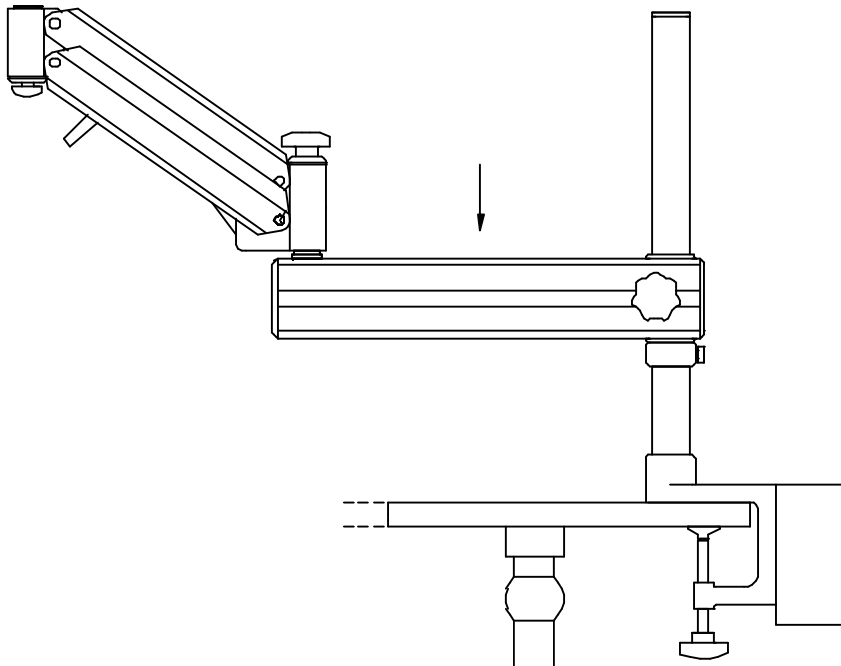

*Figure 4* Attaching the arm assembly

ISSUE NUMBER: 5.0	SUPERSEDES ISSUE: 4.1	WRITTEN BY: RJK	CHECKED BY: RDW
DATE: 11/04/02	DATE: 02/01/02	DATE: 08/10/98	DATE: 08/10/98

- Remove the microscope assembly from the case and locate it in the end of the arm assembly. Tighten the collet knob to secure the microscope (see figure 5).

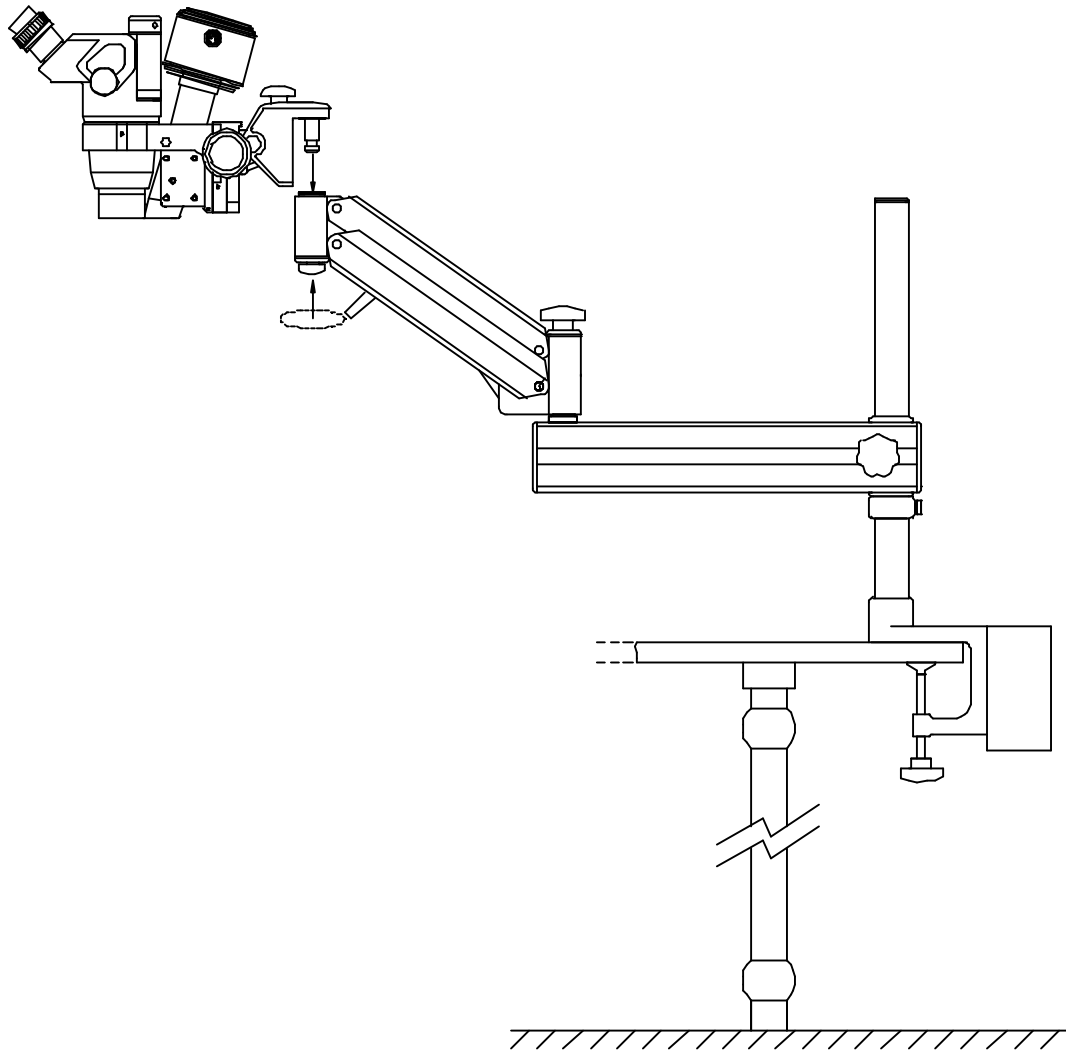

*Figure 5* Attaching the microscope assembly

ISSUE NUMBER: 5.0	SUPERSEDES ISSUE: 4.1	WRITTEN BY: RJK	CHECKED BY: RDW
DATE: 11/04/02	DATE: 02/01/02	DATE: 08/10/98	DATE: 08/10/98

7. Attach the female socket on the lamphouse cable to the connector on the side of the lamphouse. Pass the lamphouse cable through the clips on the arm assembly and plug into the power supply. This will ensure the cable does not obstruct the surgeon or come into contact with the sterile area (see figure 6).

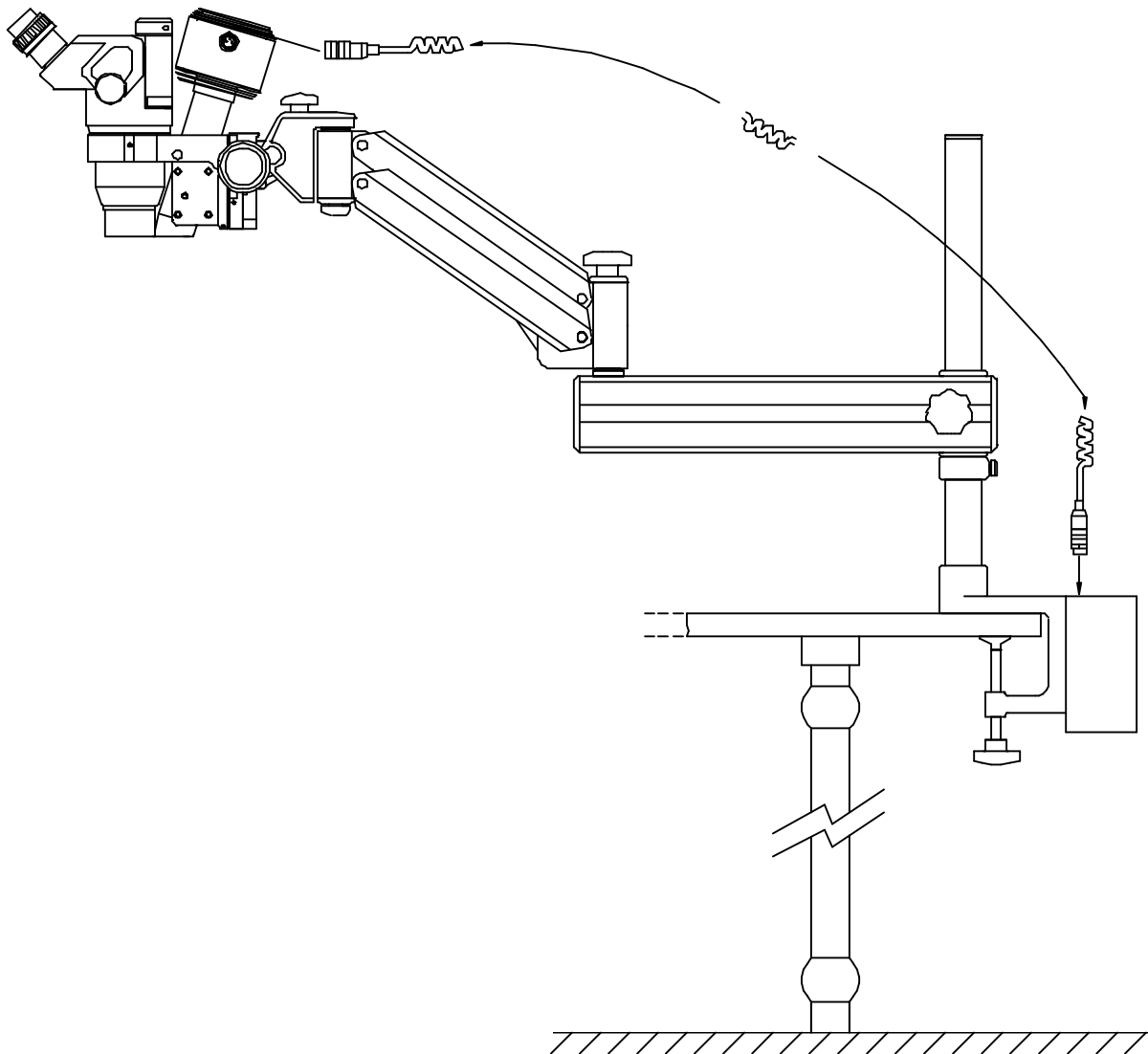

Figure 6 Connecting the lamphouse cable

ISSUE NUMBER: 5.0	SUPERSEDES ISSUE: 4.1	WRITTEN BY: RJK	CHECKED BY: RDW
DATE: 11/04/02	DATE: 02/01/02	DATE: 08/10/98	DATE: 08/10/98



8. Plug the mains power cable into the power supply and into a mains power socket. International safety standards do not allow the use of an extension cord (see figure 7).

**M**     **The mains power supply must have a protective earth conductor.** If there is no earth conductor, or if the integrity of the earth conductor arrangement is in doubt, the equipment must be operated from a 12Vdc power source.

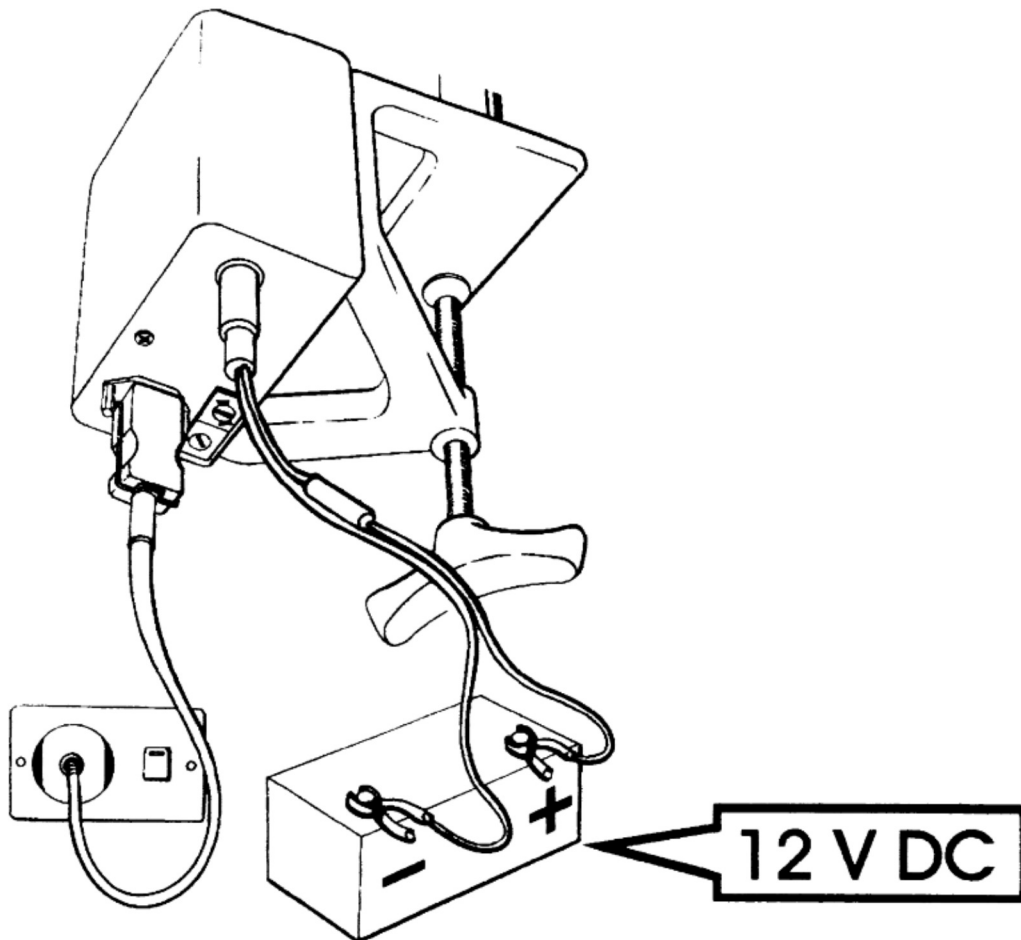

*Figure 7*     Connecting the power supply

9. Switch on the mains power supply at the wall socket.

**M**     When the ON/OFF switch is selected to ON, the power supply indicator will light.

ISSUE NUMBER: 5.0	SUPERSEDES ISSUE: 4.1	WRITTEN BY: RJK	CHECKED BY: RDW
DATE: 11/04/02	DATE: 02/01/02	DATE: 08/10/98	DATE: 08/10/98

10. Remove the microscope eyepiece blanks and insert the eyepieces (see figure 8).
  - M Retain the eyepiece blanks for repacking the microscope. Do not discard the eyepiece blanks.
  - M Take care to protect the lamphouse prism at all times. If placing the microscope assembly on a bench, lie carefully on one side.
11. Focus the microscope roughly by tilting the arm up or down to the best vertical position (see figure 8).

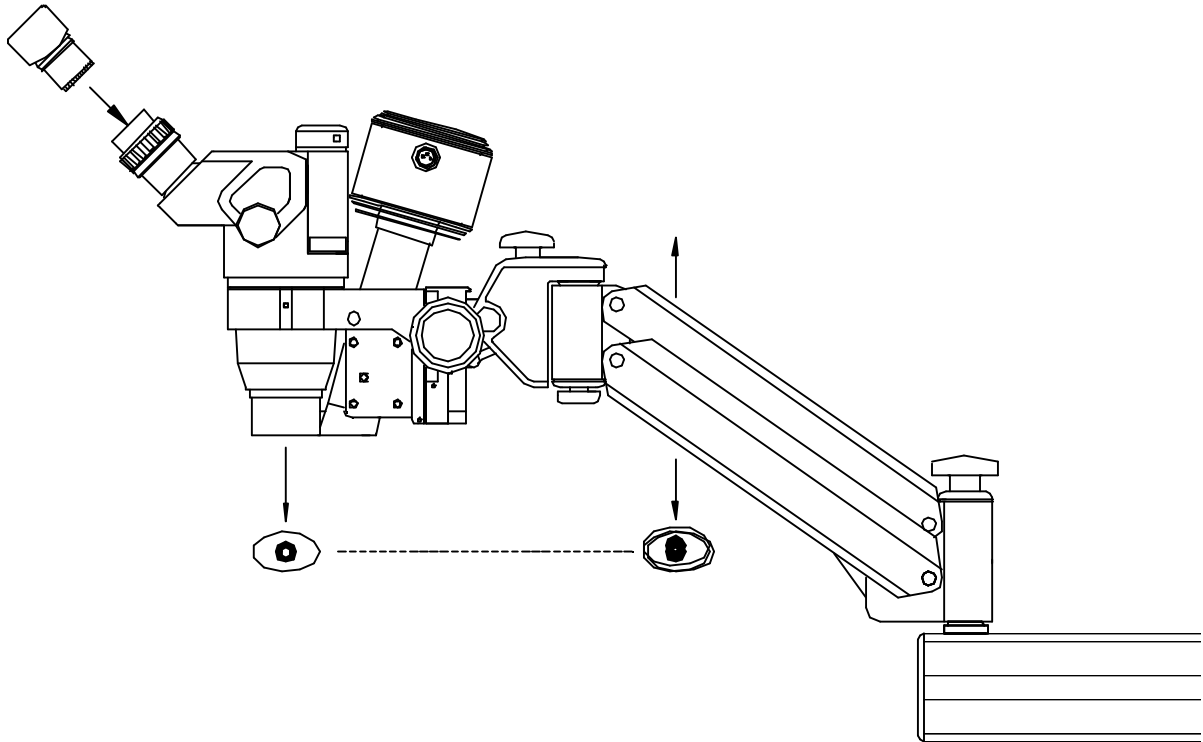

*Figure 8* Inserting the eyepieces and rough focusing

12. Check that the eyepieces are located at a comfortable viewing level. If not, rotate the tilt adjustment knob clockwise to tilt the microscope assembly down, or anticlockwise to tilt the microscope assembly up.

ISSUE NUMBER: 5.0	SUPERSEDES ISSUE: 4.1	WRITTEN BY: RJK	CHECKED BY: RDW
DATE: 11/04/02	DATE: 02/01/02	DATE: 08/10/98	DATE: 08/10/98

13. Remove two (large) focus control covers and two (small) zoom control covers from the bag inside the case. Push them into position on to the focus control knobs and zoom control knobs respectively (see figure 9).

M Focus control covers and zoom control covers are intended to be sterilised before any operating procedures.

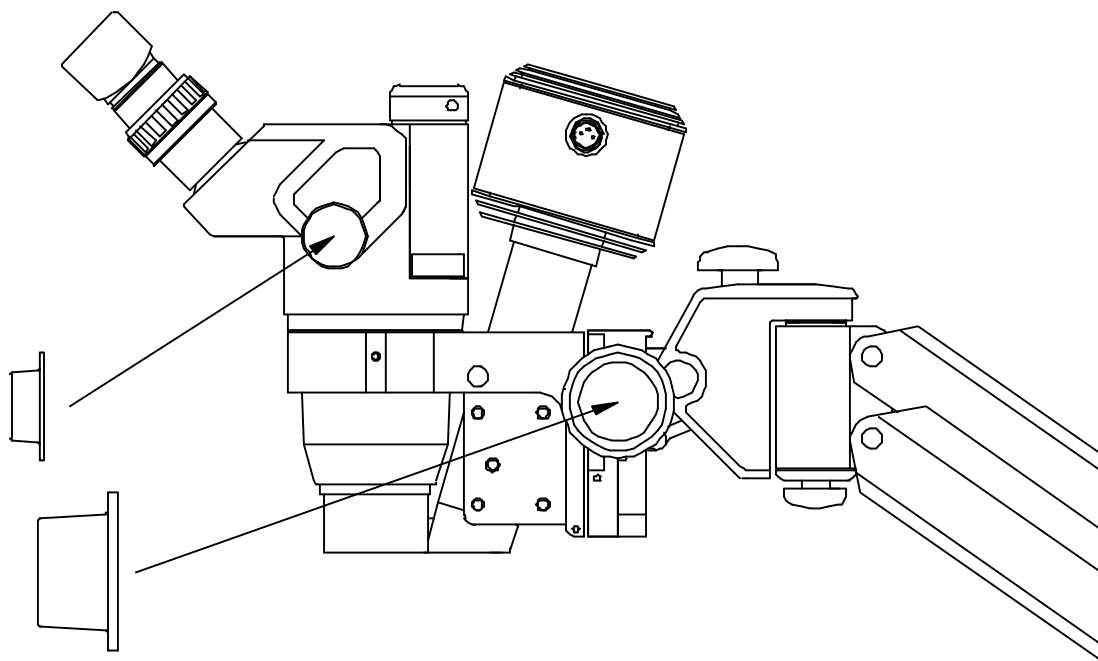

Figure 9 Inserting the Focus and Zoom Control Covers

14. Switch on the power supply and observe the light patch produced. If the patch of light is brighter to one side, it can be easily adjusted. Insert a 3mm socket key in the hole in the lamphouse cover above the 'bulb adjust' label, so that it engages in the socket of the adjusting screw. With the lamp on, turn the screw a small amount to the left or right until the patch of light is even. Small amounts of adjustment should be sufficient. Do not force the screw.

## 12 VOLT DC SUPPLY

The Scan Optics Ophthalmic Microscope may be connected to either an earthed mains (110-120V or 220-240V) ac supply, or a 12V dc supply, or both. If both supplies are connected, the battery will act as an emergency backup for mains power. In this case, the microscope will not run from battery power unless the mains supply fails or falls by more than 20 percent, or is switched off. If mains power is restored, the microscope will resume using mains power automatically. The mains power switch on the microscope does not switch the battery off.

There is some reduction in light output when the battery is connected through the power supply. If the 12V supply is to be used in isolation, or if the mains power has completely failed, the light output may be increased by connecting the battery cable directly to the lamphouse cable, bypassing the power supply.

ISSUE NUMBER: 5.0	SUPERSEDES ISSUE: 4.1	WRITTEN BY: RJK	CHECKED BY: RDW
DATE: 11/04/02	DATE: 02/01/02	DATE: 08/10/98	DATE: 08/10/98

**CONNECTING THE POWER SUPPLY TO A 12-VOLT DC SUPPLY (BATTERY)**

1. If the power supply is to be connected to a 12-volt dc supply, remove the battery cable from the case.
2. Connect the cable to the 12-volt connector on the underside of the power supply (see figure 7).
3. Connect the red battery clip to the positive battery terminal, and the black clip to the negative battery terminal. The power supply will not operate if the terminals are reversed (see figure 7).

M Earthing is not required when a 12-volt supply is used alone.

M The 12-volt supply must be direct current. The power supply will not operate with 12 volts alternating current.

M A battery with 7 amp hour capacity, such as a motor cycle or emergency lighting battery will provide about 3.5 hours life at the maximum brightness setting.

**DISMANTLING AND REPACKING THE MICROSCOPE**

1. Switch off the mains power.
2. Remove the mains power and 12-volt cables and repack.
3. Remove the microscope eyepieces and replace them into the toolbox. This will ensure the eyepieces are not dropped when the microscope assembly is removed.
4. Insert the eyepiece blanks in the microscope assembly.
5. Unplug the lamphouse cable from the power supply.
6. Reset the focus adjustment all the way down.
7. Remove the focus control covers and zoom control covers and repack or sterilise immediately if necessary.
8. Remove the microscope assembly and carefully repack. Take care to protect the lamphouse prism.
9. Remove the arm assembly, and rotate the arm about the elbow until it lies parallel with the horizontal arm. Push the arm down flat and tighten the arm lock to keep it flat. Repack the arm assembly in the case.
10. Unclamp the remaining assembly from the table and slide the safety clamp down. Replace the clamp assembly in the case.

ISSUE NUMBER: 5.0	SUPERSEDES ISSUE: 4.1	WRITTEN BY: RJK	CHECKED BY: RDW
DATE: 11/04/02	DATE: 02/01/02	DATE: 08/10/98	DATE: 08/10/98

## USE OF THE MICROSCOPE

The equipment must be located more than 25 cm away from any medical gas system or disinfection or degreasing system containing flammable vapour. The power supply must also be protected from liquid splashes and spills.

### INITIAL POSITIONING

1. Set the instrument approximately in position by swinging the elbow as required.
2. Set the focus adjustment to the midway position by aligning the focus mid-position marks on the fixed and moving parts of the focusing system.
3. Adjust the height of the microscope by moving the arm vertically so that the work area is approximately in focus. Tighten the arm and elbow locks.
4. Check the eyepiece setting to ensure clear vision with each eye separately, and set the pupillary distance. Note that the working distance is increased by rotating both eyepieces in a clockwise direction, and reduced by rotating both eyepieces counter-clockwise. The working distance may also vary with the zoom setting.
5. The microscope can now be swung aside.

### POSITIONING DURING USE

1. Swing the microscope over the patient
2. Hold the focus control knobs to move the microscope to the correct position. The most accurate focusing can be obtained at the highest magnification, as the depth of focus is then minimised.
3. Tighten the pillar lock knob until the microscope is prevented from moving freely, but is still able to be moved when required. The friction of the arm and elbow locks should be adjusted so that the movement feels uniform in all directions.
4. Focus the microscope by moving the optical head or by turning the focus control knobs, and choose the magnification by turning the zoom control knobs.
5. To swing the microscope out of the way, undo the pillar lock knob and swing the microscope about the pillar. It will remain in focus when returned to the work area.

ISSUE NUMBER: 5.0	SUPERSEDES ISSUE: 4.1	WRITTEN BY: RJK	CHECKED BY: RDW
DATE: 11/04/02	DATE: 02/01/02	DATE: 08/10/98	DATE: 08/10/98

**CAUTION:**

When the Microscope is in use it is essential that:

- M The collet knob which locks the microscope head to the arm is securely tightened.
- M The safety clamp is positioned directly under the fixed arm and is locked.

**Failure to observe these precautions may allow the microscope head to fall, with risk of harm to the patient**

**STERILISATION**

The detachable focus control covers and zoom control covers may be sterilised by:

- M boiling
- M autoclaving
- M chemical sterilisation
- M gas sterilisation.

The anodised and plated metal components can be wiped with any of the normal disinfectants.

The plastic parts and the paintwork of the microscope assembly and the power supply may be affected by organic solvents. Do not autoclave or wipe with organic solvents such as ether, xylene or alcohol; to clean use water-based solvents only.

One set of focus control covers and zoom control covers can be sterilised while the other is in use.

**NOTE: National authorities may require the use of specific sterilisation or disinfection methods.**

ISSUE NUMBER: 5.0	SUPERSEDES ISSUE: 4.1	WRITTEN BY: RJK	CHECKED BY: RDW
DATE: 11/04/02	DATE: 02/01/02	DATE: 08/10/98	DATE: 08/10/98

## CARE AND MAINTENANCE

### CARE OF THE OPTICAL HEAD

1. *Cleaning the optical components.*

The eyepieces should be checked for cleanliness each time the instrument is used. Surface dust should be removed with a clean, soft brush. Fingerprints or grease may be removed by lightly wiping with a cotton cloth or lens tissue moistened with a 70:30 mixture of absolute alcohol (either ethanol or methanol) and ether. **Do not use acetone as it may damage the surface coating.**

2. *Cleaning the plastic parts and paintwork.*

Use water based cleaners only.

**Do not use any organic solvent such as alcohol, ether or xylene.**

3. *Protection against mould.*

In hot and humid climates it is common for mould to grow on optical surfaces. Cleaning and repairing the damage can be expensive and inconvenient. To minimise the risk of mould forming, do not leave the instrument without either eyepieces or eyepiece blanks inserted and always store the optical head in a sealed bag containing silica gel desiccant. In tropical climates, routine annual maintenance of the optical head is recommended.

4. *Do not dismantle.*

No parts inside the optical head of the instrument can be serviced by the user. Attempts to dismantle the optical head or prism cover will make any warranty void.

### FUSE CHANGE

1. Turn off the mains power at the switch and remove the mains power cable as a precaution.
2. Open the fuse housing on the underside of the power supply with a coin or screwdriver.
3. Remove the old fuse, checking for failure.
4. Replace the fuse with an M205 (20 x 5mm) anti-surge type fuse, rated at 1 amp and 240 volts. Do not replace the fuse with a fuse of a higher rating.
5. Secure the fuse housing with the coin or screwdriver.
6. Replace the mains power cable and switch on to check operation.

ISSUE NUMBER: 5.0	SUPERSEDES ISSUE: 4.1	WRITTEN BY: RJK	CHECKED BY: RDW
DATE: 11/04/02	DATE: 02/01/02	DATE: 08/10/98	DATE: 08/10/98

## CARE OF THE LAMP

The lamp supplied has a rated average life of 2,000 hours.

The actual life of the lamp will depend on the intensity setting normally used. The highest setting is an over-run setting which increases light output but reduces lamp life to about 350 hours.

It is strongly recommended that the lamp be replaced as a routine maintenance task, to reduce the possibility of failure during surgery.

The Scan Optics SO-111 Ophthalmic Microscope uses lamps that are readily available in most countries.

## LAMP REPLACEMENT

1. Ensure that the lamphouse and lamp are cool to the touch.
2. Remove the lamphouse door by placing both thumbs in the groove and pushing in the direction of the 'push to open' label. Pry the lamp from the lamp holder.
3. Replace the lamp with a new lamp. Refer to the specifications for exact lamp type.
  - M The replacement lamp must be rated for 12 volts and not more than 20 watts. Use of a lamp of higher wattage may cause damage.
  - M The lamp must be handled with gloves or a tissue. If touched with bare fingers, it must be cleaned with alcohol before switching on or the life of the lamp may be substantially reduced.
4. **There may be some variation in the position of the filament with different lamps. When the lamp is replaced it may be necessary to adjust the lamp position in the lamp holder, to ensure that the filament is correctly centred and so produce a uniform area of illumination.**
  - M In general, a clearance of about 1mm will be needed between the envelope of the lamp and the lamp holder.
5. Replace the lamphouse door by pushing it back into place.
6. Switch on the power supply and observe the light patch produced. If the patch of light is brighter to one side, it can be easily adjusted. Insert a 3mm socket key in the hole in the lamphouse cover above the 'bulb adjust' label, so that it engages in the socket of the adjusting screw. With the lamp on, turn the screw a small amount to the left or right until the patch of light is even. Small amounts of adjustment should be sufficient. Do not force the screw.

ISSUE NUMBER: 5.0	SUPERSEDES ISSUE: 4.1	WRITTEN BY: RJK	CHECKED BY: RDW
DATE: 11/04/02	DATE: 02/01/02	DATE: 08/10/98	DATE: 08/10/98



## FOCUS FRICTION

The focusing system should allow the microscope head to be lowered and raised smoothly and easily, but should not allow the head to fall under its own weight. The friction of the focusing system may be adjusted as follows:

- M Simply hold the plain (left) focus control knob and rotate the right focus control knob (marked "tension") until the desired friction is achieved. To increase the friction rotate the knob clockwise, to decrease the friction rotate the knob anti-clockwise.

## POWER SUPPLY

In many countries the mains voltage fluctuates widely. Low voltage can greatly reduce the light output, and high voltage can greatly reduce lamp life. The Scan Optics power supply provides a constant voltage to the lamp for a wide range of mains power voltages.

Quartz halogen lamps have very low resistance when cold. The starting current can thus be very high, and the lamp filament may fail when turned on. The Scan Optics power supply provides a "soft start" with a ramped initial voltage to increase lamp life.

## MOULD PELLETT REPLACEMENT

1. Loosen the grub screws (no. 1 below) holding the head (2) into the universal arm (4).
2. Lift the head out of the universal arm.
3. Remove the cover plate (3) at the back of the head.
4. Peel the old pellet off of the inside wall and replace with the new pellet.
5. The new pellet should go on the right hand side of the head.
6. Replace the cover plate and secure the head back into the universal arm.

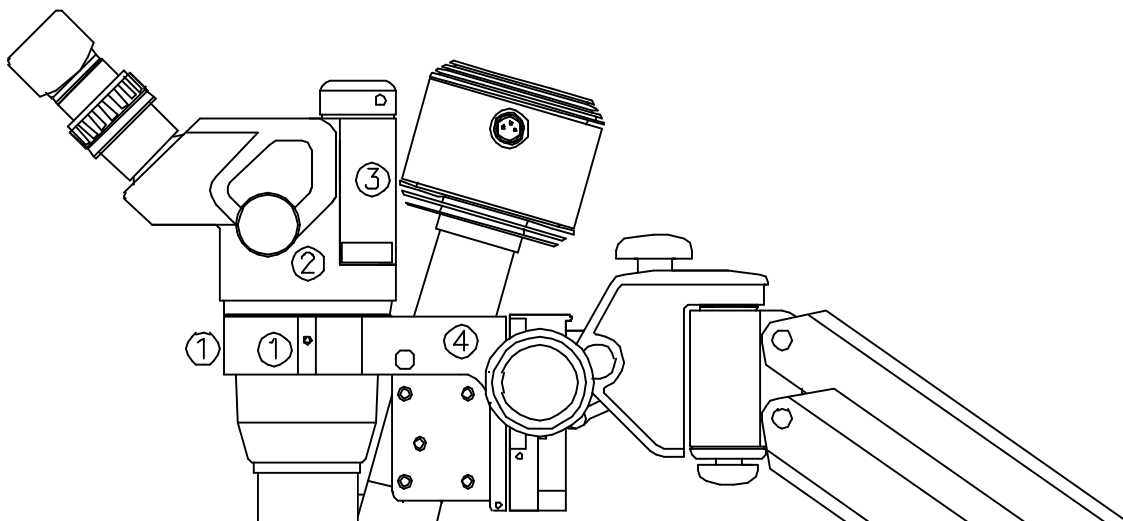

Figure 10 Mould pellet replacement

ISSUE NUMBER: 5.0	SUPERSEDES ISSUE: 4.1	WRITTEN BY: RJK	CHECKED BY: RDW
DATE: 11/04/02	DATE: 02/01/02	DATE: 08/10/98	DATE: 08/10/98

## INSTALLING CAMERA EQUIPMENT

### VIDEO CAMERA AND MONITOR

1. Set up the microscope according to the instructions.
2. Slide the second safety clamp on to the pillar and tighten lock.
3. Slide the mounting arm onto the pillar and rest on top of the safety clamp.
4. Screw the stand on to the mounting arm using the screws provided.
5. Fix the monitor to the stand using the captive screw at the top of the stand.
6. Adjust the position of the arm so that the monitor is at eye level, and move the safety clamp under the arm as necessary. Adjust the stand as necessary to angle the monitor.
7. Remove the black cap on top of the microscope head and attach the camera assembly in its place. Keep the cap in a safe place.
8. Attach the 'Y' cable to the power adapter cable using the in-line connectors. Connect the small right-angled power plug to the monitor DC in socket and the large straight power plug to the camera DC in socket. Plug the power adapter in to a mains socket using a mains plug adapter as necessary. Note that the power adapter will automatically detect mains voltages between 100 and 240V, 50-60Hz. Refer to figure 11.
9. Connect the Monitor (AV in) to camera (video out) using the video cable. Switch the moitor on. Refer to figure 11.
10. Note that the moitor may be connected to a video recorder to tape camera output. To connect to a video recorder, use the AV out socket located below the AV in socket on the monitor, and connect to the AV in of your video recorder.
11. Bring the right eyepiece of the microscope into focus.
12. Adjust the left eyepiece to focus.
13. If the picture on the monitor is unfocussed, adjust focus at rear of the SZ-CTV attachment below the camera. Refer to figure 11.
14. If the picture is at an angle, loosen the retaining screw and rotate the camera assembly in its mount until the picture is upright. Re-tighten the screw.
15. Adjust the picture using the brightness, contrast, and colour controls located on the side of the monitor.

ISSUE NUMBER: 5.0	SUPERSEDES ISSUE: 4.1	WRITTEN BY: RJK	CHECKED BY: RDW
DATE: 11/04/02	DATE: 02/01/02	DATE: 08/10/98	DATE: 08/10/98

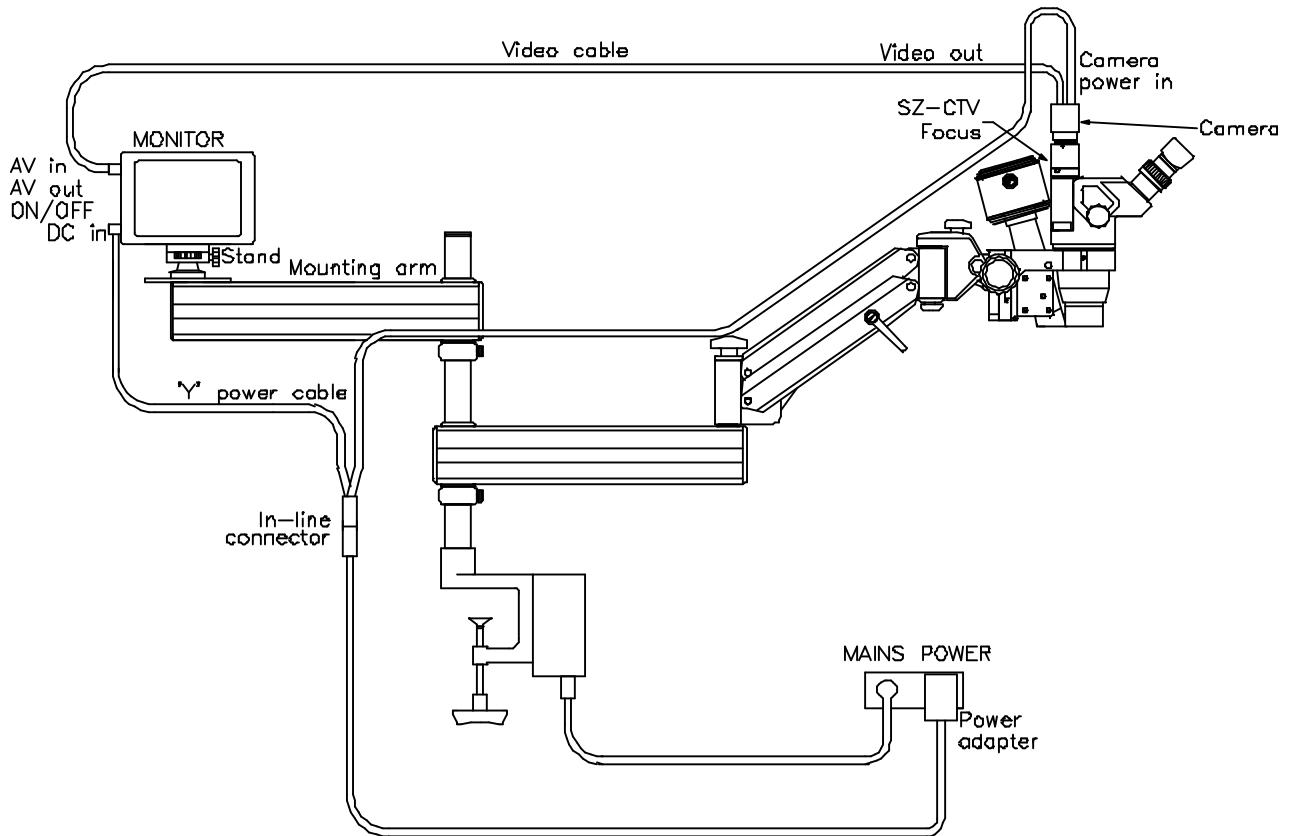

Figure 11 Scan Optics SO-111 Video System Schematic

ISSUE NUMBER: 5.0	SUPERSEDES ISSUE: 4.1	WRITTEN BY: RJK	CHECKED BY: RDW
DATE: 11/04/02	DATE: 02/01/02	DATE: 08/10/98	DATE: 08/10/98

**ATTACHING THE 35MM CAMERA ADAPTER**

Refer to figure 12.

1. Remove the protective plastic cap on the trinocular attachment (B) by unscrewing the fasteners located on either side.
2. Attach the photo tube (C) on the trinocular attachment as shown and secure by screwing the fasteners back in.
3. Carefully insert the photo eyepiece (D) into the photo tube. Note that the photo eyepiece **must** be removed from the photo tube if the assembly is to be transported.
4. Attach the photomicro adapter (E) to the photo tube and secure by tightening the knob on the bottom of the adapter.
5. Attach the camera (F) on the top of the photomicro adapter.
6. Attach the Vari-Magnifier and/or remote cord as required.

**DISASSEMBLING THE 35MM CAMERA ADAPTER**

1. To disassemble the photographic apparatus, simply perform the steps above in reverse. Note that the photo eyepiece **must** be removed from the photo tube when the apparatus is dismantled.
2. Take care to ensure that protective caps provided with the components (e.g. photo tube, trinocular attachment) are replaced after use.

ISSUE NUMBER: 5.0	SUPERSEDES ISSUE: 4.1	WRITTEN BY: RJK	CHECKED BY: RDW
DATE: 11/04/02	DATE: 02/01/02	DATE: 08/10/98	DATE: 08/10/98

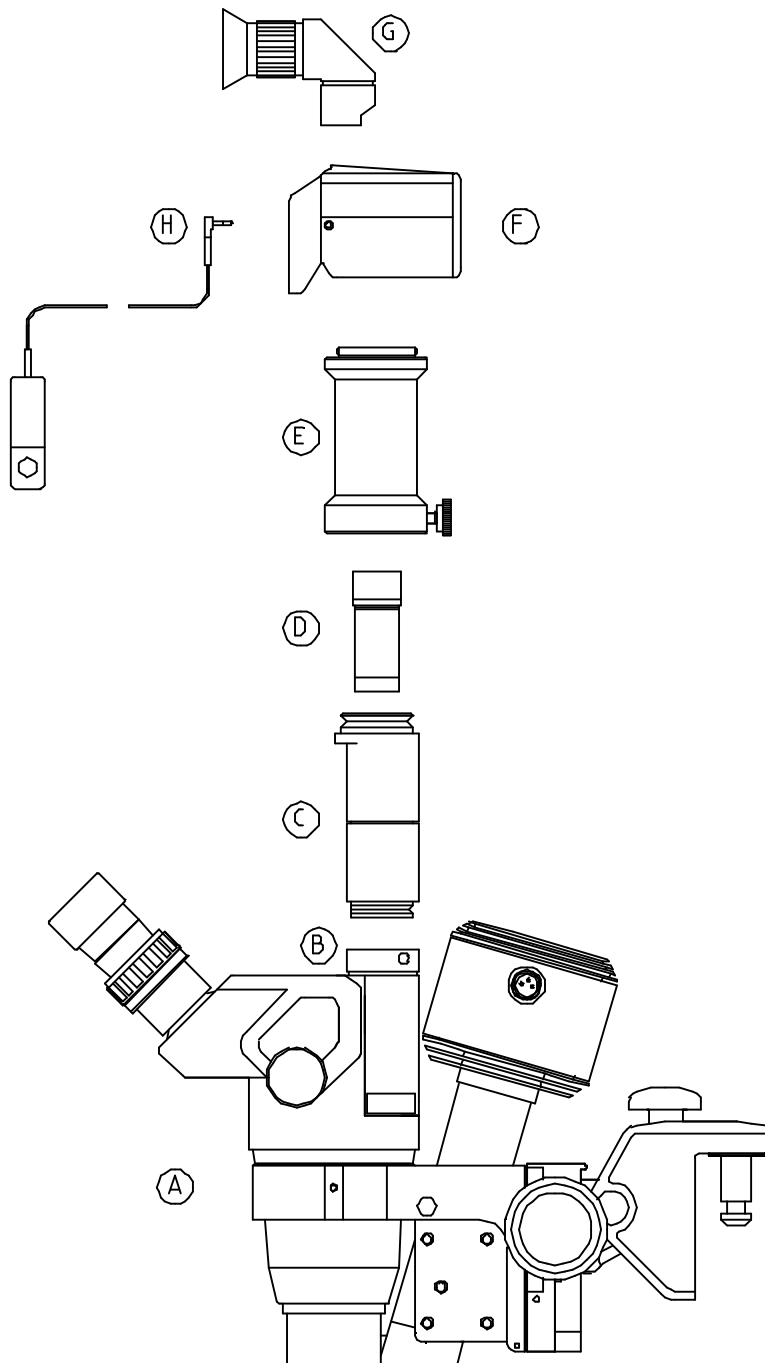

## KEY TO FIGURE 12:

- A: Scan Optics SO-111  
Microscope head and  
lamphouse assembly
- B: Olympus SZ-TRU  
trinocular attachment
- C: Olympus SZ-PT photo  
tube
- D: Olympus NFK 2.5 x LD  
photo eyepiece
- E: Olympus OM-mount  
photomicro adapter L
- F: Olympus SC 35 Camera
- G: Olympus MFVS  
Vari-Magnifier
- H: Olympus M Remote  
cord

Figure 12 Assembling the 35mm camera attachments

ISSUE NUMBER:	5.0	SUPERSEDES ISSUE:	4.1	WRITTEN BY:	RJK	CHECKED BY:	RDW
DATE:	11/04/02	DATE:	02/01/02	DATE:	08/10/98	DATE:	08/10/98

## BINOCULAR ASSISTANT MICROSCOPE

The optional assistant microscope allows an observer to view procedures under magnification within close proximity of the operating field. In order to fit the assistant microscope, first attach the mounting bracket provided to one side of the microscope head using the four M5x10 socket head cap screws provided. Then insert the mounting arm and secure it with the locking pin. Refer to figure 11.

Sterilisable covers are provided to fit over the focus knobs.

Pupillary distance adjustment is performed manually, but the eyepieces are not geared together. For the best user comfort, ensure that the eyepieces are equidistant from the central axis of the main optical path.

The adjustable eyepiece may be used to compensate for any refractive error difference between the left and right eye of the user. First, rotate the adjustable (left) eyepiece so that there are equal amounts of adjustment on either side. Then focus the microscope while closing the left eye and looking only through the right eyepiece. When the microscope is focussed, close the right eye and look with the left eye through the left eyepiece, and rotate the adjusting ring until the left eye is focussed.

When the microscope is fitted to the side of the main microscope head, a tilt angle of approximately 30 degrees will enable the visual field of the assistant microscope to match that of the main microscope head. To adjust this angle, loosen the angle lock knob while holding the microscope head, tilt the head to the appropriate angle and lock it again. Small sideways adjustments of the visual field can be achieved by loosening the microscope lock knob and rotating the microscope head about its mounting axis. When the fields are aligned correctly, tighten the microscope lock knob once again.

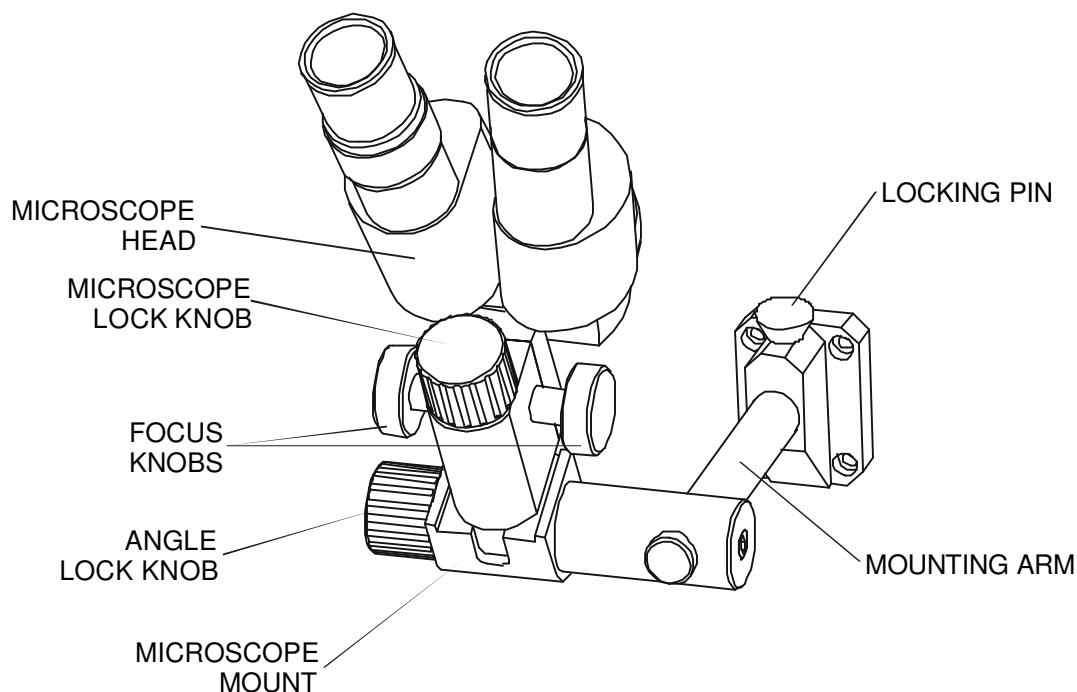

Figure 13 Binocular Assistant Microscope

ISSUE NUMBER: 5.0	SUPERSEDES ISSUE: 4.1	WRITTEN BY: RJK	CHECKED BY: RDW
DATE: 11/04/02	DATE: 02/01/02	DATE: 08/10/98	DATE: 08/10/98

### MOUNTING THE BINOCULAR ASSISTANT MICROSCOPE

The assistant microscope may be configured to mount on either the left or right side of the main microscope head. Figure 11 shows the head configured to fit on the right hand side of the microscope head. In order to swap the mounting configuration follow figures 12a and 12b shown.

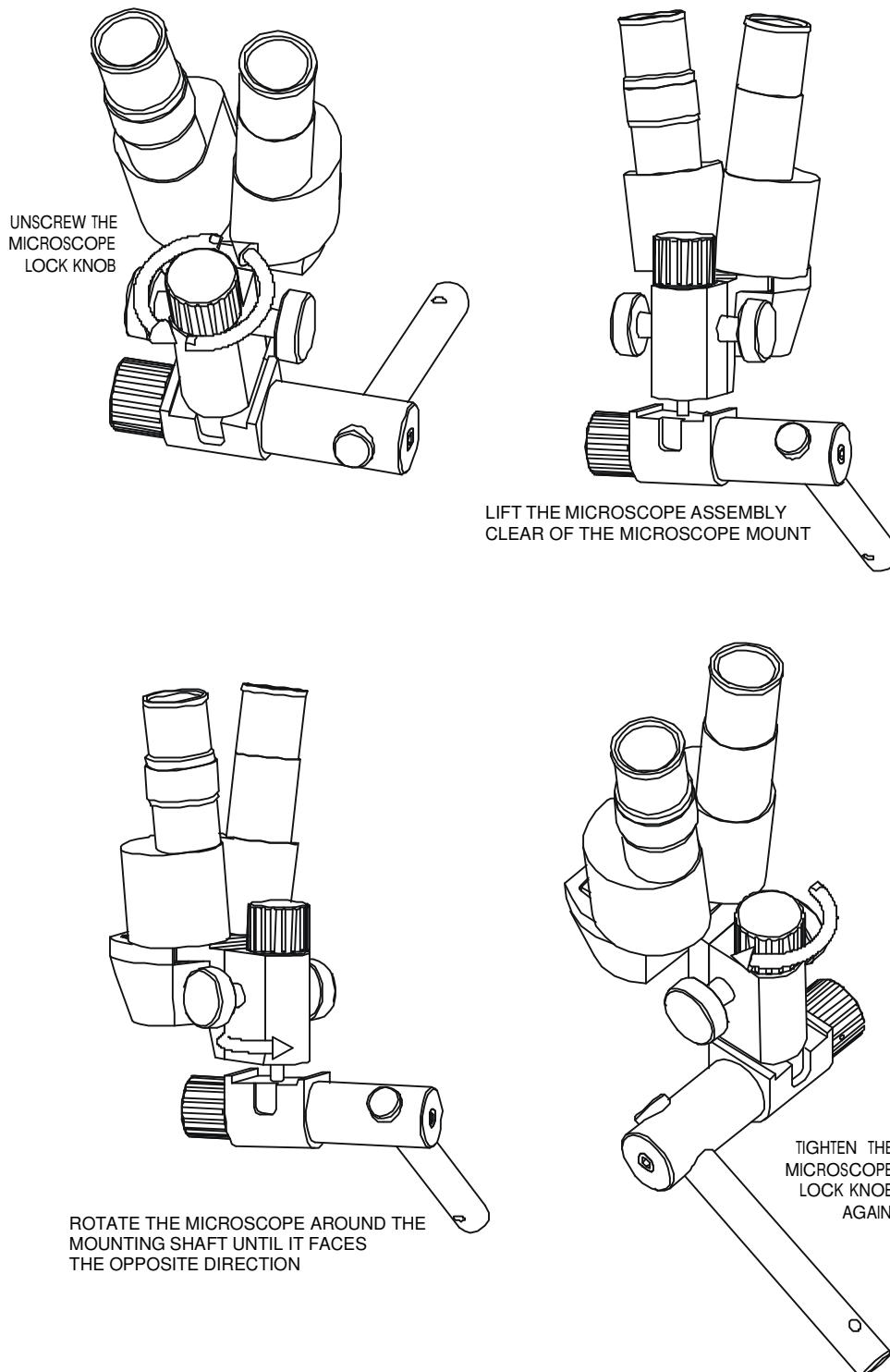
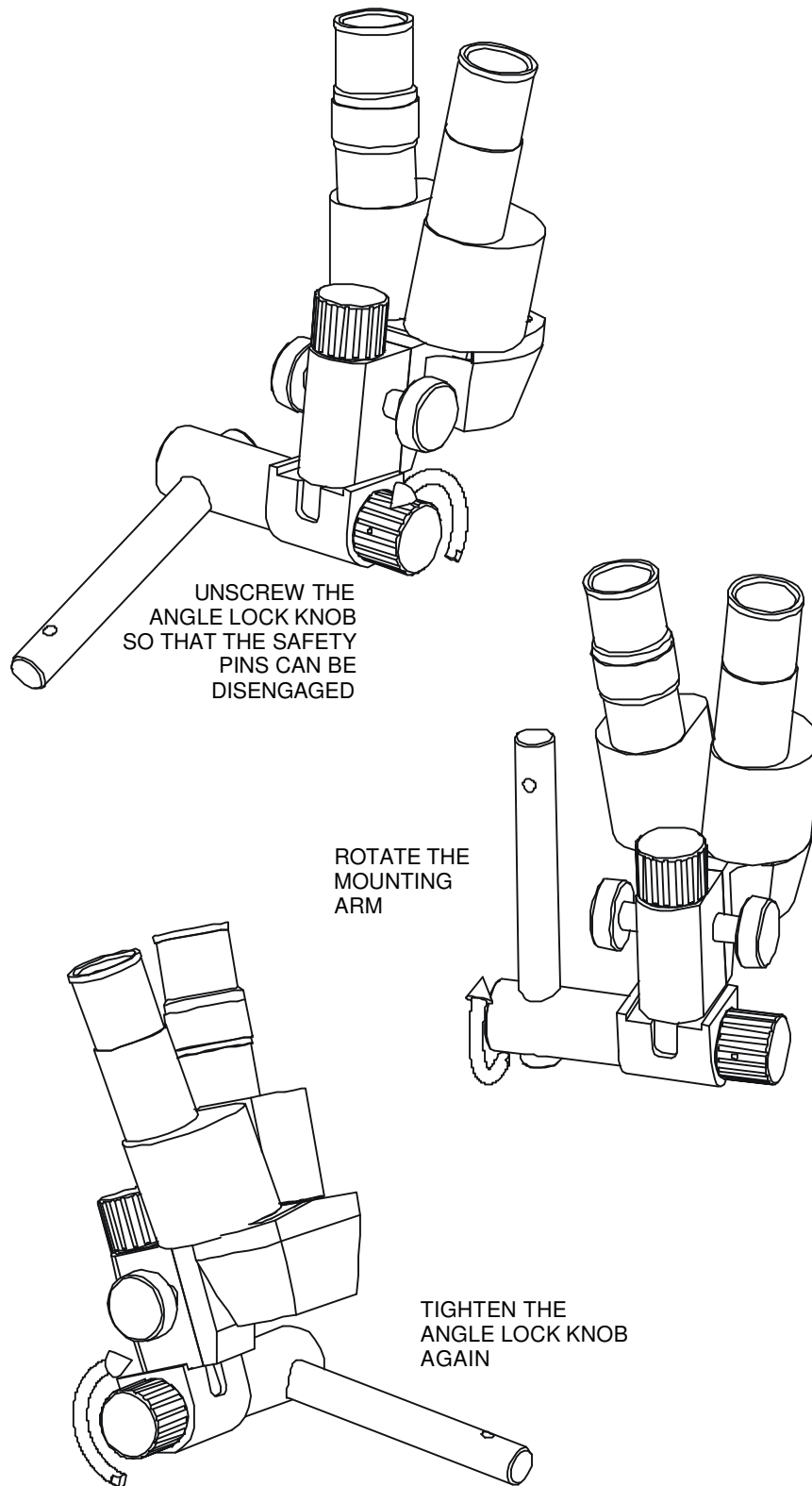

Figure 14a Changing the assistant microscope configuration

ISSUE NUMBER:	5.0	SUPERSEDES ISSUE:	4.1	WRITTEN BY:	RJK	CHECKED BY:	RDW
DATE:	11/04/02	DATE:	02/01/02	DATE:	08/10/98	DATE:	08/10/98



*Figure 14b* Changing the assistant microscope configuration

ISSUE NUMBER:	5.0	SUPERSEDES ISSUE:	4.1	WRITTEN BY:	RJK	CHECKED BY:	RDW
DATE:	11/04/02	DATE:	02/01/02	DATE:	08/10/98	DATE:	08/10/98



## TROUBLESHOOTING

	<b>SYMPTOM</b>	<b>CAUSE</b>	<b>REMEDY</b>
1.	Lamp does not operate	Blown fuse	Check power indicator light on switch, (if fuse blown, indicator light will not glow) check and replace fuses as necessary
		Mains power failure	Check power indicator light on switch, use 12V dc battery
		Battery failure	Check battery voltage and replace or recharge as necessary
		Battery terminals incorrectly wired	Wire terminals correctly (red (+) positive; black (-) negative)
		Lamp failure	Replace lamp
2.	Mains fuse blows repeatedly	Mains voltage incorrectly set	Set mains voltage to correct setting
3.	Lamp dim	Battery low	Recharge battery
		Lamp filament not centred	Adjust lamp position to centre filament
		Lamp blackened	Replace lamp
		Mains voltage incorrectly set	Set mains voltage to correct setting
		Mould on optical surfaces	If mould is evident, return microscope to Scan Optics for servicing
4.	Focusing difficult	Stiff focus knob	Adjust focus friction
		Focus system falls under own weight	Adjust focus friction
5.	Blurred view	Dirty eyepieces	Clean eyepieces
		Mould on optical surfaces	If mould is evident, return microscope to Scan Optics for servicing
		Dislodged prism due to shock load	Rotate lamphouse prism to correct location parallel to eyepieces. Contact Scan Optics.

ISSUE NUMBER: 5.0

SUPERSEDES ISSUE: 4.1

WRITTEN BY: RJK

CHECKED BY: RDW

DATE: 11/04/02

DATE: 02/01/02

DATE: 08/10/98

DATE: 08/10/98

	<b>SYMPTOM</b>	<b>CAUSE</b>	<b>REMEDY</b>
6.	Microscope unstable	G-clamp loose	Tighten G-clamp
		Mounting surface unstable	Use more rigid mounting surface
		Arm/Elbow will not lock in place	Check presence of friction (curved) washers interleaved with flat washers under Arm/Elbow knob(s)
		Microscope head movement/vibration	Check microscope correctly seated in collar
7.	Microscope uncomfortable to use	Eyepieces too high	Use tilt adjust knob and tilt as necessary

ISSUE NUMBER: 5.0

SUPERSEDES ISSUE: 4.1

WRITTEN BY: RJK

CHECKED BY: RDW

DATE: 11/04/02

DATE: 02/01/02

DATE: 08/10/98

DATE: 08/10/98

## SPECIFICATIONS

### OPTICAL HEAD

VIEWING SYSTEM	Binocular, stereoscopic (convergence angle 12°) Eyepiece tube inclination 45°
MAGNIFICATION	Zoom magnification, range 4.2 x - 25x Control knobs removable for sterilisation
WORKING DISTANCE	Lamphouse prism to object distance 165mm
FIELD OF VIEW	15 - 65mm, depending on magnification
REFRACTIVE ERROR	Adjustment +6° to -8°, each eyepiece
FOCUSING	Range ± 28mm Control knobs removable for sterilisation
INTERPUPILLARY DISTANCE	Adjustable for Distance PD range approximately 50 to 80mm

### LAMPHOUSE

ALIGNMENT	Coaxial with viewing system
LAMP	12V 20W quartz-halogen lamp with G4 base and horizontal filament. Colour temperature 2,925 degrees K
<i>Example</i>	GE M47 12V 20W <i>Note: this is the only lamp now recommended by Scan Optics as suitable for use in the microscope lamphouse.</i>
AVERAGE LAMP LIFE	High Intensity (voltage over-run): 350 hours Medium (rated voltage): 2,000 hours
LAMP CHANGE	Plug in for fast change, no screws
ILLUMINATION	35,000 Lux approximately at maximum setting.

ISSUE NUMBER: 5.0	SUPERSEDES ISSUE: 4.1	WRITTEN BY: RJK	CHECKED BY: RDW
DATE: 11/04/02	DATE: 02/01/02	DATE: 08/10/98	DATE: 08/10/98

**POWER SUPPLY**

MAINS POWER	100-120V or 220-240V ac, selectable by external switch on each unit
OUTPUT	Regulated output with soft start.
INTENSITY CONTROL	Continuously adjustable
EARTHING	Via earth lead of power cable (green/yellow)
DIRECT CURRENT	12 V dc source optional, automatically selected if mains voltage falls by 20%
FUSE	M205 (20 x 5mm) 1A at 240 volts rating anti-surge fuse on primary winding of transformer
CABLES	<i>Mains:</i> Length 5 metres
	<i>Battery:</i> Length 5 metres

**MOUNTING SYSTEM**

CLAMP	Opening 75mm, throat 100mm
EXTENSION	Bed surface to focal plane, maximum 270mm Bed edge to optic axis, maximum 570mm
MOUNT SIDE	Left or right hand

**CASE**

DIMENSIONS	700 x 490 x 200mm (27.5 x 19.3 x 7.9")
WEIGHT	Instrument only 8kg (18 lbs) Instrument packed with case and accessories 20 kg (44 lbs)

ISSUE NUMBER: 5.0	SUPERSEDES ISSUE: 4.1	WRITTEN BY: RJK	CHECKED BY: RDW
DATE: 11/04/02	DATE: 02/01/02	DATE: 08/10/98	DATE: 08/10/98

## SO-1370 CAMERA SPECIFICATIONS

### WATEC WAT-202B CCD

- ü Ultra Miniature, High Resolution Colour Camera
- ü 1/3" pick-up element for wide field and high resolution
- ü white balance selection for incandescent lamp
- ü 12 volt d.c. power input

SYSTEM	PAL
HORIZONTAL RESOLUTION	More than 420 TV lines
PICTURE ELEMENTS	795 (H) x 596 (V)
LENS MOUNT	"CS" Mount
DRIVE FREQUENCY	15.625kHz (H), 50Hz (V)
SCANNING SYSTEM	2:1 interlaced
VIDEO OUT	1 Vp-p 75ohm unbalanced
MINIMUM ILLUMINATION	3 lux F1.2 (high gain position)
POWER REQUIREMENT	12VDC $\pm$ 10%, 150mA Power from battery or mains adaptor on SO-111 microscope.
OPERATING TEMPERATURE	-10 to +40°C
DIMENSIONS	43.4 x 44 x 65.5mm
WEIGHT	150g

ISSUE NUMBER: 5.0	SUPERSEDES ISSUE: 4.1	WRITTEN BY: RJK	CHECKED BY: RDW
DATE: 11/04/02	DATE: 02/01/02	DATE: 08/10/98	DATE: 08/10/98

## SO-1380 MONITOR SPECIFICATIONS

### TFT LCD

ü CE Marked

ü Tested to comply with FCC standards.

FUNCTIONS	AV in, AV out Optional TV tuner Optional PAL or NTSC versions.
SCREEN SIZE	130 x 99 mm (W x H), diagonal 165 mm (6.5")
POWER REQUIREMENT	12V dc, < 850mA. Universal power adaptor supplied.
OPERATING TEMPERATURE	0 to 60°C
DIMENSIONS	189 x 131 x 36.5 mm (WxHxD)
WEIGHT	480g

ISSUE NUMBER: 5.0	SUPERSEDES ISSUE: 4.1	WRITTEN BY: RJK	CHECKED BY: RDW
DATE: 11/04/02	DATE: 02/01/02	DATE: 08/10/98	DATE: 08/10/98

